



SpitzLift Package Description Document

(Product Cut Sheet/ Install Guide)

PACKAGE DESCRIPTION: DODGE PROMASTER REAR DOOR FOLD-DOWN SPITZLIFT **MAX LOAD CAPACITY:** 650 LBS / 295 KG

PACKAGE ID #: OPTION 1 - PM **Right side (Curb Side) Install** **PACKAGE ID #:** OPTION 1 - PM **Left side (Driver Side) Install**

VEHICLE SPECIFIC PACKAGE **VEHICLE MAKE** DODGE **VEHICLE MODEL** PROMASTER **START YEAR** 2016



PACKAGE IMAGE

PACKAGE SPECIFICATIONS:

Dodge Promaster Rear Door Fold-Down SpitzLift
Option 1 - PM
Installs on either Left or Right Side
Install Weight: Approx. 81 lbs
Load Capacity: 650 lbs
Includes:
12V DC 3ft. Fold-Down Crane LTD-3QRT with Pendant, DC Connect & Wiring Harness, 13" Pivot Tube Z-LTPT13 (taller option available), Pedestal KBPSG-010-030 with Installation Reinforcement Kit KBP-1012-DPH

SHIPPING WEIGHTS:

BOX 1 50 **LBS** **BOX 2** 46 **LBS** **BOX 3** 10 **LBS** **BOX 4** **LBS**

SPECIAL NOTES:

SPITZLIFT VAN PACKAGE: DODGE PROMASTER REAR DOOR (2016 FORWARD)
 RIGHT SIDE (CURB SIDE) | LEFT SIDE (DRIVER SIDE) KBPSRG-010-030

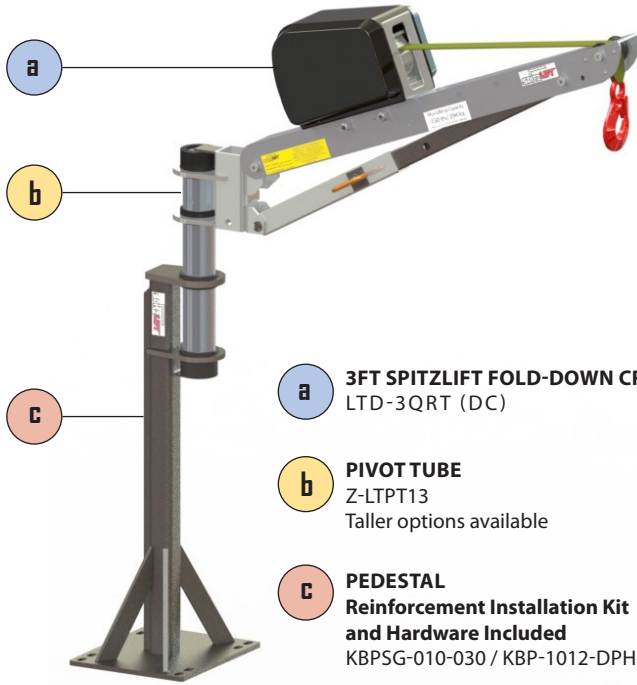

- a** 3FT SPITZLIFT FOLD-DOWN CRANE LTD-3QRT (DC)
- b** PIVOT TUBE Z-LTPT13
Taller options available
- c** PEDESTAL Reinforcement Installation Kit and Hardware Included
KBPSG-010-030 / KBP-1012-DPH



3 FT SPITZLIFT FOLD-DOWN CRANE - DC POWERED	SPECIFICATIONS
MAX LIFTING CAPACITY	650 LBS (294.8 KG)
MANUFACTURING STANDARDS	COMPLIANT WITH OSHA AND ASME STANDARDS
ROTATION	360°
WEBBING OR WIRE ROPE	20' (609.6 CM) 50' (1524 CM)
LIFTING SPEED	DC - 22'6"(6.858 M)/MIN (0.11/SEC)
DC PENDANT CONTROLLER	10' (304.8 CM)
INSTALLED WEIGHT	DC - 91 LBS (41.28 KG)
POWER REQUIREMENTS	12V DC @ 70 AMPS
STANDARD FINISH	CLEAR ANODIZED POWDER COATED
MATERIAL	AIRCRAFT GRADE ALUMINUM & STEEL
WARRANTY	3 YEARS LIMITED



DC Pendant Controller

Item#: 25559-REMOTE10HK
 Length: 10' (304.8 CM)



DC Quick Connect

Item#: 24085-4
 Length: 4' (121.9 CM)



DC Wiring Harness

Item#: 01-C-100000
 Length: 35' (1066.8 CM)



Reinforcement Kit

Item#: KBP-1012-DPH

*Manual Handcrank Option available upon request.

SPITZLIFT VAN PACKAGE: DODGE PROMASTER REAR DOOR (2016 FORWARD)

RIGHT SIDE (CURB SIDE) | LEFT SIDE (DRIVER SIDE) KBPSG-010-030

MAX CAPACITY 650 / 295 KG



INSTALLATION GUIDE

DC OR MANUAL CRANE PEDESTAL INSTALLATIONS

Installation document reflects curb side install.

Can be installed on driver side.

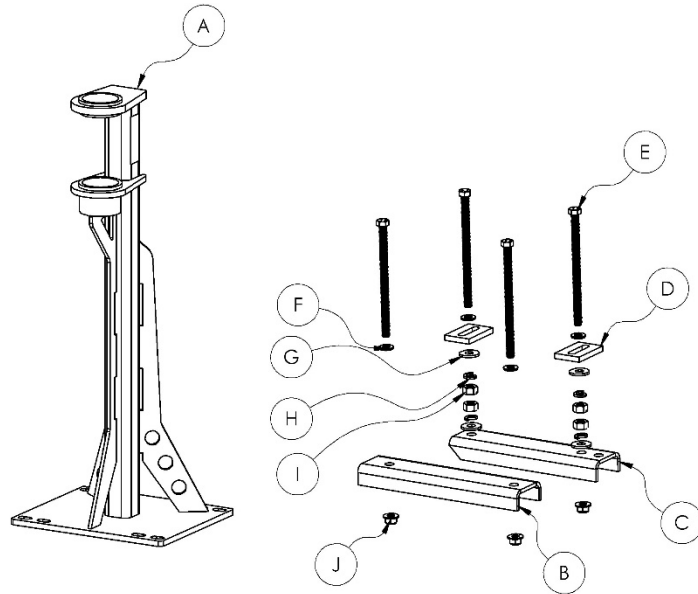

REF	Part Description	Qty
A	KBPSG-010-030	1
B	PLATE, HK BRKT PROMASTER 1	1
C	PLATE, HK BRKT PROMASTER 2	1
D	PLATE, HK SPACER 3 X 2,	2
E	HEX HEAD SCREW, 1/2-13 X 8.0, G5 ZINC	4
F	WASHER, 1/2" SEALING NEOPRENE, GALV	4
G	WASHER, 1/2" USS ZINC	4
H	SPLIT LOCK WASHER, 1/2" ZINC	4
I	HEAVY HEX NUT, 1/2-13, G5 ZINC	4
J	FLANGED HEX NUT, 1/2-13 NYLOC, ZINC	4

DISCLAIMER: It is recommended that SpitzLift pedestals be professionally installed. SpitzLift is not responsible for the structural integrity of the mounting structure.

CAUTION: Ensure that the location for the pedestal is clear of all wires, harnesses, lines, fuel tank, etc.

Step 1.

- Determine pedestal location indicated in (fig I) dimensions. Confirm that door closes completely. There should be a 2.5" gap between closed door and .25" gap from rear corner. Set pedestal into position and mark holes as indicated in (fig II).
- Drill 17/32 (.53) hole at positions 1 and 4 as seen in (fig I) and (fig II).
- Use two 8" Hex Bolts (item E) provided to hold pedestal in place.

Note: All drilled holes must be properly sealed by liberally applying high grade silicone or other sealant around the perimeter of all holes. If silicone is applied properly, silicone will squeeze out. Remove excess silicone after completion of installation.

Step 2.

- Place first bracket (item B) into position and lock into place as indicated using the Flange Hex Nuts (item J) (fig III-1 & 4). Slightly tighten.

Step 3.

- Drill hole 2 and 3 as seen in (fig II).
- Use the remaining two 8" Hex Bolts (item E) to hold pedestal in place.

Step 4.

- Bolt locations 2 and 3. Use Spacers (item D), Lock Washers (item H), and Nuts (item J) to tighten up to body floor/deck, (fig III-5).
- Run second nut, lock washer, and flat washer beyond the top of channel bracket location (item C) which will be tightened down for the last step to lock channel bracket into place. Place channel bracket as shown in (fig III & fig IV).
- Use Flanged Hex Nut (item J). Tighten bolts locations 2 and 3 evenly to keep bracket level. Also tighten 1 and 4 once all bottom nuts have been securely tightened.
- Tighten the second nut down to the top of the channel (item C). Confirm all bolts are securely tightened (fig IV).

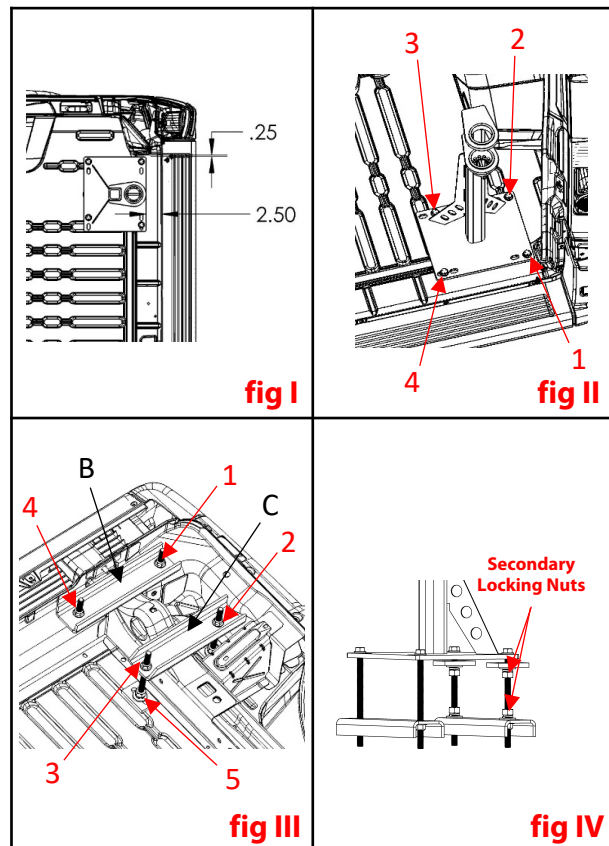

SPITZLIFT VAN PACKAGE: DODGE PROMASTER REAR DOOR (2016 FORWARD)

RIGHT SIDE (CURB SIDE) | LEFT SIDE (DRIVER SIDE) KBPSG-D10-030

MAX CAPACITY 650 / 295 KG



Step 5.

When pedestal is installed to the vehicle, ensure that everything is structurally sound and that all holes are sealed with silicone.

Step 6. SpitzLift Automotive Grade Wiring Harness Installation (For DC powered installations, supplied with SpitzLift DC cranes)

DC Wiring Harness components (**SpitzLift PN#01-C-100000**)

- 35 ft. power cable, 8 ft. ground cable.
- #8 wire (600v rating UL Type MTW VW-1)
- 70amp (2 qty 35amp) circuit breakers (avg. current draw 50amps)
- Anderson (SB-50) connector



- Run wiring harness along the chassis of the vehicle. Make certain that both lead wires are properly attached along chassis without sagging and are secured from being pinched.
- Use rubber grommets on any hole penetrations. Ensure that the cable does not contact any heat sources that could cause damage.
- Attach 8 ft. ground lead to chassis. Ensure ground connection is to bare metal, paint, or seal connection after termination
- Run positive 25 ft. lead, which includes automatic circuit breakers, and terminate to positive battery connector or to auxiliary lug.
- Position power supply connector for plugging the SpitzLift extension power cord (4 ft. standard length **SpitzLift PN#24085-4**) onto the side wall in a location that is unobstructed within 2' of the SpitzLift power unit (**fig V**).

Step 7.

Insert SpitzLift into the pedestal and perform recommended load test. 125% of max capacity.

Step 8. (Securing crane for travel)

- **For Fold-Down Cranes**, place crane in folded position and insert hook into eye of pedestal. Reel webbing or cable in to tighten and secure (**fig V**).
- **For Non-Folding Cranes**, locate a connecting point with in the vehicle to attach the hook. Reel in webbing or cable in to tighten and secure. **May require installation of a tie-down for attaching hook.*

Note: If crane continues to chatter, tighten the strap a little more. Caution– do not over tighten.

Step 9.

Unplug power cord for travel and when crane is not in use.

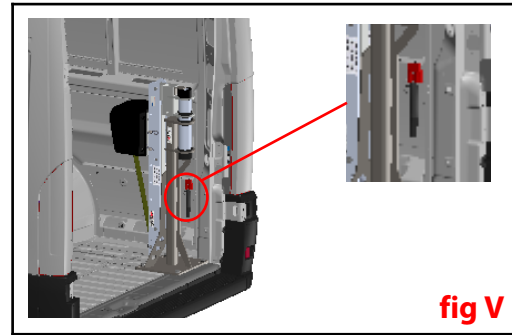

fig V